

Development of Portable Emission Analyzer



Author(s)

Nauman Farooq	19-ME-08
Muhammad Hamza	19-ME-09
Raja Numan Jhangir	19-ME-31
Ahsan Ali Khan	19-ME-49

Advisor

Dr. Mubashir Gulzar

Associate Professor

DEPARTMENT OF MECHANICAL ENGINEERING

**FACULTY OF MECHANICAL AND AERONAUTICAL
ENGINEERING**

UNIVERSITY OF ENGINEERING AND TECHNOLOGY

TAXILA

July 2023

Abstract

During the industrial era, the extensive use of gasoline and diesel fuels had numerous advantages, including providing energy and boosting economic development. However, their negative impact on the environment, particularly air pollution, is significant. Air pollution is a critical issue that affects both the environment and human health, leading to increased energy consumption and reduced energy production by solar panels. The health effects of air pollution can be both short-term and long-term. Portable emission analyzers are small, lightweight devices that are utilized to measure the levels of various pollutants present in the air. They can measure a broad range of pollutants such as carbon monoxide, nitrogen oxides, sulfur dioxide, and particulate matter, among others. Our aim of this projects is to develop a portable emission analyzer for measuring air pollutants.

Keywords: Analyzer, Emission, Environmental Sustainability, Pollution

Acknowledgements

This section is the most preferable for us because we have got the opportunity to say thanks and gratitude to some beautiful people in our life.

Our First deepest gratitude goes to **Pakistan Engineering Council (PEC)** who supported us financially to explore such a great opportunity. We are also grateful to our supervisor **Dr. Mubashir Gulzar** for giving us the valuable opportunity to do our project under his supervision. We are grateful to him for trying us to follow an advance research standard and guiding us always to meet the high research standards. His knowledge and calm nature make us happy and proud to remain his student. Very special gratitude goes our Parents for their encouragement, and precious support throughout our whole educational carrier.

We would like to say special thanks to honorable Dr. Mubashir Gulzar once again. We not only learned good research skills by him but also very valuable life skills. He gave us that motivation level who could not be given by anyone else. He always served us with his precious time with full effort and support. We are very happy and proud to be his student.

United Nations Sustainable Development Goals

The Sustainable Development Goals are a call for action by all countries – poor, rich and middle-income – to promote prosperity while protecting the planet. They recognize that ending poverty must go together with strategies that build economic growth and address a range of social needs including education, health, social protection, and job opportunities, while tackling climate change and environmental protection. Check the appropriate SDGs related to the project.



SDGs		Tick the appropriate SDG
Quality Education		
Clean Water and Sanitation		
Affordable and Clean Energy		
Decent Work and Economic Growth		
Industry, Innovation, and Infrastructure		
Sustainable Cities and Communities		
Responsible Consumption and Production		
Climate Action		

Table of Contents

Abstract.....	ii
Acknowledgements.....	iv
Abbreviations.....	x
Chapter 01: Introduction.....	1
1.1: Complex Engineering Problem Statement.....	3
1.2: Aim and Objectives	3
Chapter 02: Literature Review.....	4
2.1: Combustion Process in Engine:	5
2.1.1: NO _x Formation:	7
2.1.2: Carbon Monoxide Formation:.....	8
2.2: Detection Devices:	9
2.2.1: Oxygen Sensors:.....	9
2.2.2: CO Sensors:.....	12
2.2.3: NO _x Detection Sensors:.....	14
2.3. Measured Emissions of Different Engines:	15
2.3.1 Comparison Based on Engines and Fuels:	17
2.4. Why did we choose to measure only CO and NO _x :	18
Chapter 03: Methodology:.....	20
3.1 Determine the pollutants of interest:	20
3.2 Choose sensors:.....	20
3.3 Model the analyzer:.....	21
3.4 Assemble the analyzer:	21
3.5 Calibrate the analyzer:	21
3.6 Test the analyzer:	23
Chapter 04: Experimental Setup:.....	24

4.1 Parts:	24
4.1.1 Gas Sampling Pipe:	24
4.1.2 Filtration System:	25
4.1.3 Gas Storage Tank (Constructed with PVC Pipe):	25
4.1.4 Gas Sensors:	26
4.1.5 Temperature Module:	30
4.1.6 Processing Unit:	31
4.1.7 Display Unit:	32
4.2 Working Method:	32
4.2.1 Gas Sensors (Ns11Na and ZE15-CO):	32
4.2.2 Temperature Module:	34
4.2.3 SD Card:	34
4.3 Code to Interact with Arduino:	36
4.4 Pins Explanation:	40
4.4.1 thermoDO (Thermocouple Data Out):	40
4.4.2 thermoCS (Thermocouple Chip Select):	40
4.4.3 thermoCLK (Thermocouple Clock):	40
4.4.4 A0 and A1 (Analog Input Pins):	40
4.4.5 0x27 (I2C Address):	41
4.4.6 4 (SD Card Pin):	41
Chapter 05: Results and Discussion:	43
5.1 Graph:	43
5.2 Discussion:	44
Chapter 06: Conclusion:	46
Reference:	48

Table of Figures:

Figure 2.1: Combustion Reaction [5].....	6
Figure 2.2: Temp vs NO _x [5]	8
Figure 2.3: Zirconia Sensor [7].....	11
Figure 2.4: Titania Sensor [7]	12
Figure 2.5: Chemical CO Sensor [8].....	13
Figure 2.6: NDIR Sensors [9]	14
Figure 2.7: NO _x sensing element (chip)	14
Figure 2.8: NO _x sensing element in longitudinal section view	15
Figure 2.9: Comparison of mean emission of CO (%) based on fuel type.	17
Figure 2.10: Comparison of mean emission NO based on fuel type	17
Figure 3.1: Working methodology.....	20
Figure 3.2: 3D model	21
Figure 4.1: Gas Sampling Pipe	24
Figure 4.2: Gas Storage Tank	25
Figure 4.3: NO _x Sensor	26
Figure 4.4: NO _x sensing element (chip)	26
Figure 4.5: NO _x sensing element in longitudinal section view	27
Figure 4.6: CO Sensor.....	28
Figure 4.7: Chemical CO Sensor [8].....	29
Figure 4.8: Temperature module.....	31
Figure 4.9: Processing Unit.....	31
Figure 4.10: Display unit	32
Figure 4.11: Working Model	36
Figure 4.12: Testing of Analyzer	42
Figure 5.1: Result of Emissions	43

List of Tables:

<i>Table:2.1 : Combustion components[5]</i>	6
<i>Table:2.2 : Comparison of mean emissions by different vehicles.</i>	16
<i>Table:4.1: Data Sheet of CO Sensor.</i>	30
<i>Table:5.1: Honda Bike emissions</i>	43

Abbreviations

AF: Air fuel ratio

CO: Carbon monoxide

CO₂: Carbon Dioxide

HC: Hydrocarbons

H₂O: Water

LCD: Liquid Crystal Display

NDIR: Non-dispersive infrared

NO_x: Nitric oxide

NO₂: Nitrogen dioxide

NO: Nitrogen oxide

O₂: Oxygen

PPM: Parts per million

Greek Symbol

Λ = Lambda

Chapter 01: Introduction

Combustion engines in their various applications remain the main source of propulsion. Aside from typical applications in on-road vehicles, combustion engines are also fitted in non-road vehicles and machines. A numerous group are small engines used in handheld devices (handheld chainsaws, lawnmowers etc.), small power generators or scooters. The number of these small engines grows rapidly, the example of which are scooters. The global market for motorcycles, scooters, and mopeds is projected to reach 61.2 million by 2020, driven by population growth, urbanization and expanding middle class population countries. Unfortunately, this is followed by an increased global fuel consumption (CO₂ emission) and exhaust emissions. It is noteworthy that small engines are a serious threat to the natural environment. The exhaust emission limits for these vehicles are more liberal compared to other on road engine applications.

An emission analyzer is a device that is used to measure the levels of pollutants that are emitted from various sources, such as industrial plants, vehicles, and power generators. These devices are critical tools for monitoring and controlling air pollution, as they provide accurate and reliable data that can be used to identify sources of pollution and develop strategies to reduce emissions.

There are many different types of emission analyzers available, each designed to measure specific pollutants or a range of pollutants. Some of the most common pollutants that are measured include carbon monoxide, nitrogen oxides, sulfur dioxide, and volatile organic compounds. Some analyzers are also capable of measuring particulate matter, heavy metals, and other pollutants.

Emission analyzers come in various types, including portable and bench-top models, and are used in a range of applications such as vehicle emission testing, industrial process control, and environmental monitoring. Portable models are typically used for on-site testing, while bench-top models are used for laboratory analysis.

One of the key features of an emission analyzer is its ability to measure the concentration of pollutants in real-time. This allows for quick and accurate readings, which can be used to make adjustments to the emission source to reduce the amount of pollutants released into the environment.

In the case of vehicle emission testing, the emission analyzer is used to measure the concentration of pollutants in the exhaust of a vehicle, typically as part of a mandatory annual inspection. The results of the emission test are used to determine whether the vehicle meets the required emissions standards.

In industrial applications, emission analyzers are used to monitor and control the emissions from processes such as combustion, incineration, and process vents. The device can be used to optimize the process to minimize emissions, reduce waste, and improve the overall efficiency of the process.

The technology used in emission analyzers is constantly evolving, with new sensors and techniques being developed to provide more accurate and precise measurements.

1.1: Complex Engineering Problem Statement

Emissions are major reason for environmental pollution. One of the main sources of these Emissions are Internal Combustion Engine. The detection of such emissions helps in minimizing the Air pollution. The requirement is the development of Emission Analyzer having suitable accuracy and portability. Extensive Literature Review, Modeling and Development of Analyzer is the requirement to be addressed in the FYDP.

1.2: Aim and Objectives

Aim:

The aim is to measure the emissions out of engine.

Objectives:

1. The selection of suitable sensor for emissions of engine
2. Fabrication of Portable Engine Emissions Analyzer

Chapter 02: Literature Review

Carbon dioxide (CO₂) and hydrocarbon (HC) emissions decreased however nitrogen oxide (NO_x) emissions increased with increasing fuel injection pressure. Lower CO₂ and HC emissions, and significantly higher NO_x emissions were observed with advanced injection timings. The hydrogen addition to gaseous or liquid fuels offers good environmental and energy performances as it was well proven in the last decade. The high-water content in fuel oil (3.5e20%) causes a combustible characteristic, while the water content of fuel oil causes a dramatic decrease in in-cylinder temperatures and heat release rates. Exhaust gases consists of CO₂, N₂ and water vapor mainly. The part of this exhaust gas is re-circulated to the engine cylinder; it acts as diluents to the combustion mixture as it replaces the amount of fresh air, it also reduces the O₂ concentration in the combustion chamber.

Analysis of exhaust gas from combustion engines can help evaluate engine performance and diagnose problems [1].

Hydrocarbons: The HC's channel is calibrated as hexane or propane depending on the vehicle type the analyzer is to be used on. The measurement itself represents unburned fuel and is measured in the ppm (parts per million). Modern automobiles in good running order frequently show 10ppm or less when evaluated with an automotive gas analyzer. Trucks and forklifts may have higher levels due to fuel type or engine style.

Carbon Dioxide: The level of CO₂ is a product of combustion and represents the amount of fully burned fuel. Therefore, a higher CO₂ level indicates a higher engine efficiency. Many fuel injection engines will show approximately 15% CO₂ [2].

Carbon Monoxide: Partially burned fuel results in CO. High CO levels indicate a ‘rich’ fuel mixture. A perfect fuel mixture meters in exactly enough fuel to consume all the O₂ entering the engine. A perfect ratio is not sustainable in real-life operation. A fuel mixture that contains excess fuel is usually referred to as a ‘rich’ condition. [3] A ‘lean’ condition refers to an excess of O₂. CO may be measured in percent or ppm amounts depending on type / age of engine.

NO_x: NO_x generally refers to NO and NO₂ (nitric oxide and nitrogen dioxide). This measurement is in ppm and represents the combustion products of burning nitrogen [4]. This occurs at the higher engine temperatures associated with a lean fuel mixture or being under load. Of the NO_x output of a typical engine, the NO component will usually make up the highest proportion.

Diesel engines are generally associated with higher NO_x and particulate emissions.

2.1: Combustion Process in Engine:

The basic combustion process can be described by the fuel (the hydrocarbon) plus oxidizer (air or oxygen) called the **Reactants**, which undergo a chemical process while releasing heat to form the **Products** of combustion such that mass is conserved. In the simplest combustion process, known as **Stoichiometric Combustion**, all the carbon in the fuel forms carbon dioxide (CO₂) and all the hydrogen forms water (H₂O) in the products, thus we can write the chemical reaction as follows:

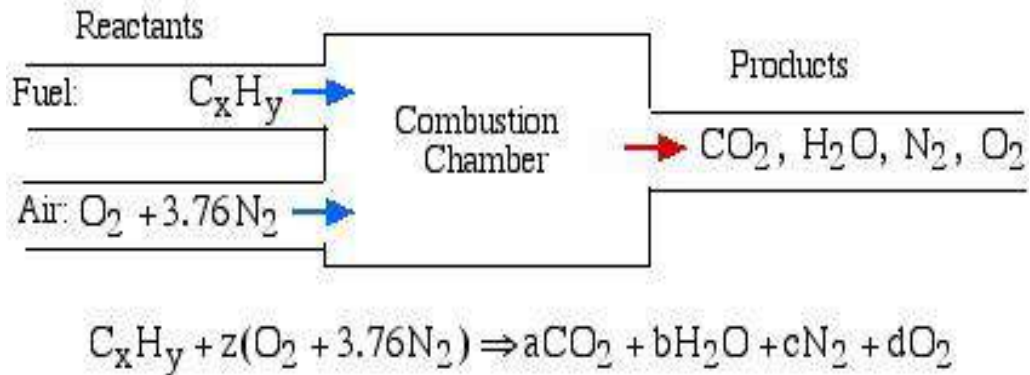

Figure 2.1: Combustion Reaction [5]

Where z is known as the stoichiometric coefficient for the oxidizer (air) [5]. Note that this reaction yields five unknowns: z , a , b , c , d , thus we need five equations to solve. Stoichiometric combustion assumes that no excess oxygen exists in the products, thus $d = 0$. We obtain the other four equations from balancing the number of atoms of each element in the reactants (carbon, hydrogen, oxygen, and nitrogen) with the number of atoms of those elements in the products. This means that no atoms are destroyed or lost in a combustion reaction.

Table:2.1 : Combustion components[5]

Elements	Amount in Reactants	Amount in Products	Reduced Equation
Carbon (C)	x	a	$a = x$
Hydrogen (H)	y	$2b$	$b = y/2$
Oxygen (O)	$2z$	$2a+b$	$z = a + b/2$
Nitrogen (N)	$2(3.76)z$	$2c$	$c = 3.76z$

Reaction of Gasoline:

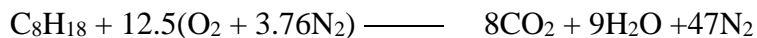

2.1.1: NO_x Formation:

Three chemical reactions form the Zeldovich reaction are:

Reaction:

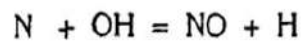
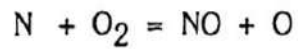
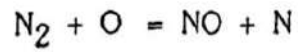

Forward rate constants

$$k_{1,f} = 1.8 \times 10^{11}$$

$$\exp(-38370/T)$$

$$k_{2,f} = 1.8 \times 10^7$$

$$\exp(-4680/T)$$

$$k_{3,f} = 7.1 \times 10^{10}$$

$$\exp(-450/T)$$

Zeldovich reaction is the most significant mechanism of NO formation in IC engines [5].

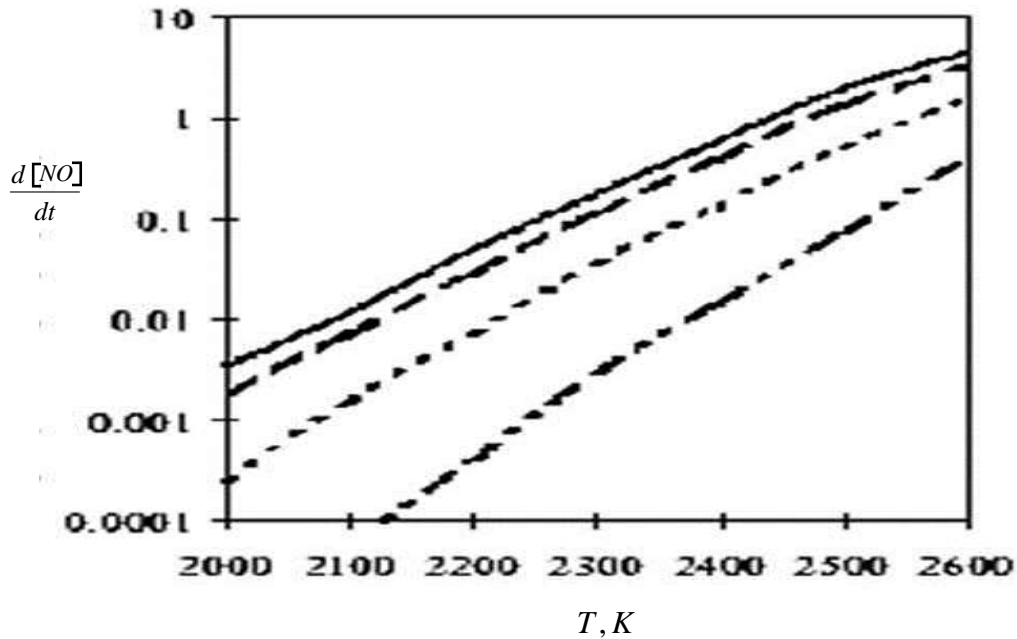
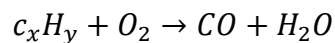

Figure 2.2: Temp vs NO_x [5]

2.1.2: Carbon Monoxide Formation:

Carbon monoxide (CO) is produced when combustion reactions are not fully completed, either through lack of oxygen or due to low mixing. Carbon monoxide is a colorless and odorless gas. All combustion sources, including motor vehicles, power stations, waste incinerators, domestic gas boilers, and cookers, emit carbon monoxide. Carbon monoxide is not poisonous but has a temporary effect on the human respiratory system. Carbon monoxide attaches itself to red blood cells, preventing the uptake of oxygen.



Carbon monoxide correlates with the oxygen content in the flue gases. Low excess oxygen increases CO formation. The higher the air ratio and the better the mixing, the lower is the CO emission. Operating with a high furnace temperature and a long residence time decrease CO emission [6]. Because carbon monoxide emission behaves in a similar way

to many other hydrocarbon emissions, it is often used for regulatory purposes as a signal for the overall efficiency of combustion. Thus, regulating CO is often associated with imposing restrictions on hydrocarbon emissions.

2.2: Detection Devices:

2.2.1: Oxygen Sensors:

The **Lambda coefficient** (λ) is obtained from the relationship between air and gasoline involved in combustion of the mixture. It is a measure of the efficiency of the gasoline engine by measuring the percentage of oxygen in the exhaust.

When gasoline engines operate with a stoichiometric mixture of 14.7: 1 the value of lambda (λ) is "1".

Mixing ratio = weight of fuel / weight of air

- Expressed as mass ratio: 14.7 kg of air per 1 kg. of fuel.
- Expressed as volume ratio: 10,000 liters of air per 1 liter of fuel.

With this relationship theoretically a complete combustion of gasoline is achieved, and greenhouse gas emissions would be minimal [10]. The coefficient is defined as Lambda coefficient If $\text{Lambda} > 1$ = lean mixture, excess of air. If $\text{Lambda} < 1$ = rich mixture, excess of gasoline.

- A lean mixture contains an excess of oxygen. The surplus oxygen will react with nitrogen to (oxides of nitrogen), if the temperature is high enough (around 1600 °C) for enough time to permit so.

- A rich mixture contains a deficit of oxygen. This makes it impossible for all fuel to combust completely to carbon dioxide and water vapor [7]. Hence, some fuel will remain as a hydrocarbon, or it will react only to carbon monoxide (CO). The carbon monoxide concentration in exhaust gases is closely related, and almost proportional to the air fuel ratio in the rich regions. It is, therefore, of great value when tuning an engine.
- Carbon dioxide emitted is theoretically directly proportional to the fuel consumed at a given and constant air fuel ratio. Less carbon dioxide will be emitted per liter of fuel if $\lambda < 1$ since some fuel won't be able to combust completely.

There are many ways of measuring oxygen. These include technologies such as **zirconia**, **electrochemical (also known as galvanic)**, **infrared**, **ultrasonic**, **paramagnetic**, and very recently, **laser methods**.

- **Zirconia sensor**

The zirconium dioxide, or zirconia, lambda sensor is based on a solid-state electrochemical fuel cell called the Nernst cell. Its two electrodes provide an output voltage corresponding to the quantity of oxygen in the exhaust relative to that in the atmosphere.

An output voltage of 0.2 V (200 mV) DC represents a "lean mixture" of fuel and oxygen, where the amount of oxygen entering the cylinder is sufficient to fully oxidize the carbon monoxide (CO), produced in burning the air and fuel, into carbon dioxide (CO₂). An output voltage of 0.8 V (800 mV) DC represents a "rich mixture", which is high in unburned fuel and low in remaining oxygen. The ideal set point is approximately 0.45 V (450 mV) DC.

This is where the quantities of air and fuel are in the optimal ratio, which is ~0.5% lean of the stoichiometric point, such that the exhaust output contains minimal carbon monoxide.

The voltage produced by the sensor is nonlinear with respect to oxygen concentration. The sensor is most sensitive near the stoichiometric point (where $\lambda = 1$) and less sensitive when either very lean or very rich.

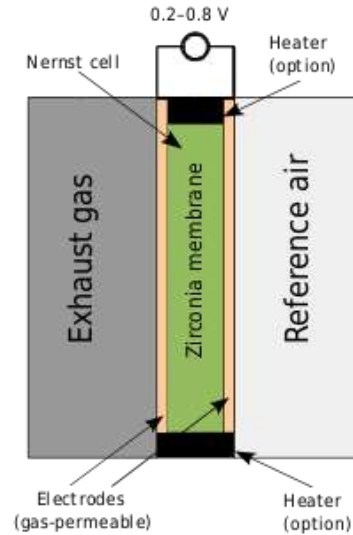

Figure 2.3: Zirconia Sensor [7]

- **Titania sensor**

A less common type of narrow-band lambda sensor has a ceramic element made of titania (titanium dioxide). This type does not generate its own voltage but changes its electrical resistance in response to the oxygen concentration. The resistance of the titania is a function of the oxygen partial pressure and the temperature. Therefore, some sensors are used with a gas temperature sensor to compensate for the resistance change due to temperature. The resistance value at any temperature is about 1/1000 the change in oxygen concentration. Luckily, at $\lambda = 1$, there is a large change of oxygen, so the resistance change is typically 1000 times between rich and lean, depending on the temperature.

As titanium is an N-type semiconductor with a structure TiO_{2-x} , the x defects in the crystal lattice conduct the charge [7]. So, for fuel-rich exhaust (lower oxygen concentration) the resistance is low, and for fuel-lean exhaust (higher oxygen concentration) the resistance is high. The control unit feeds the sensor with a small electric current and measures the resulting voltage drop across the sensor, which varies from nearly 0 volts to about 5 volts. Like the zirconia sensor, this type is nonlinear, such that it is sometimes simplistically described as a binary indicator, reading either "rich" or "lean". Titania sensors are more expensive than zirconia sensors, but they also respond faster.

In automotive applications the titania sensor, unlike the zirconia sensor, does not require a reference sample of atmospheric air to operate properly.

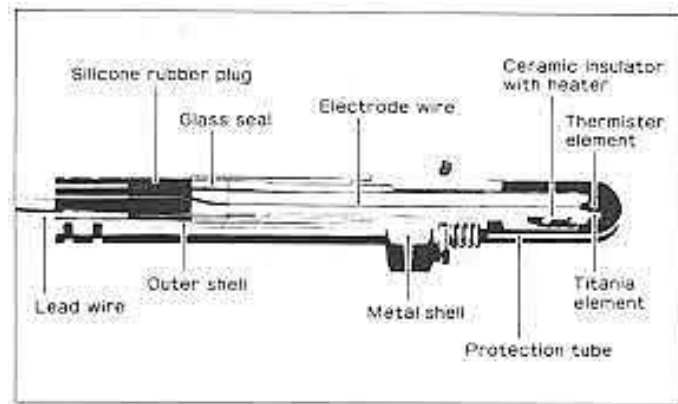

Figure 2.4: Titania Sensor [7]

2.2.2: CO Sensors:

1. Chemical CO sensors

Chemical CO gas sensors with sensitive layers based on polymer- or heteropolysiloxane have the principal advantage of a very low energy consumption and can be reduced in size to fit into microelectronic-based systems. On the downside, short- and long-term drift

effects as well as a rather low overall lifetime are major obstacles when compared with the nondispersive infrared sensor measurement principle.

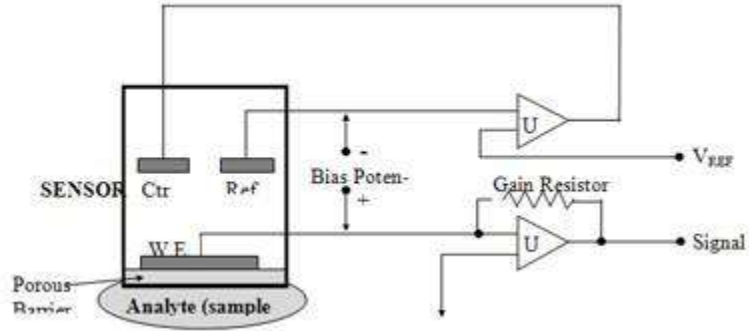

Figure 2.5: Chemical CO Sensor [8]

Another method (Henry's Law) also can be used to measure the amount of dissolved CO in a liquid, if the number of foreign gases is insignificant [8].

2. Non-dispersive infrared CO sensors (NDIR)

Nondispersive infrared sensors are spectroscopic sensors to detect CO in a gaseous environment by its characteristic absorption. The key components are an infrared source, a light tube, an interference (wavelength) filter, and an infrared detector. The gas is pumped or diffuses into the light tube, and the electronics measures the absorption of the characteristic wavelength of light. Sensors are most often used for measuring carbon monoxide. The best of these has sensitivities of 20–50 PPM

Most CO sensors are fully calibrated prior to shipping from the factory. Over time, the zero point of the sensor needs to be calibrated to maintain the long-term stability of the sensor [9]. New developments include using microelectromechanical systems to bring

down the costs of this sensor and to create smaller devices. Typical sensors cost in the (US) \$100 to \$1000 range.

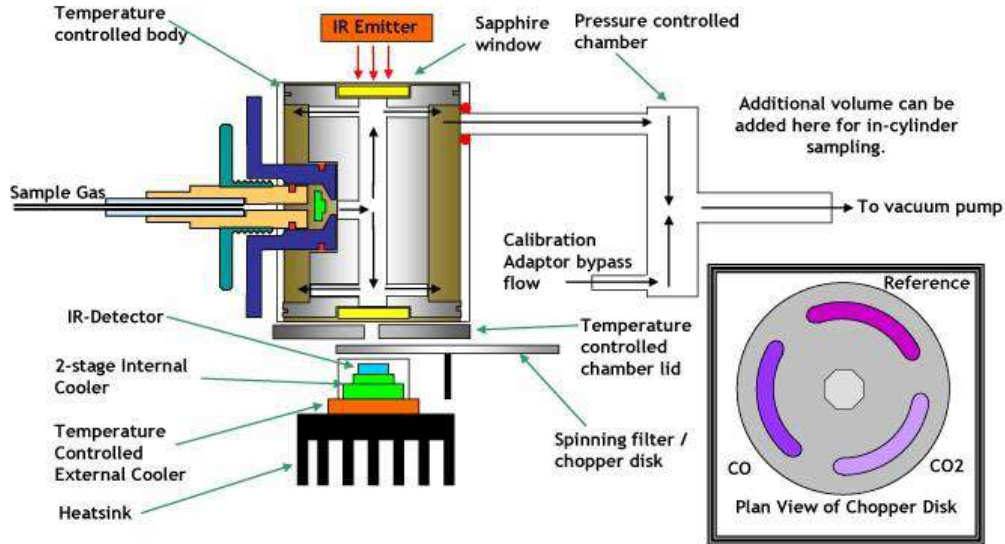

Figure 2.6: NDIR Sensors [9]

2.2.3: NO_x Detection Sensors:

Common methods for measuring NO_x include sensor technologies based on chemiluminescence and electrochemical techniques. The electrochemical technique cannot measure NO and NO₂ at one time. Chemiluminescence requires conversion of NO₂ to NO for measurement of the NO₂ content based on an assumed NO: NO₂ ratio. In addition, measurements can be affected by the content of H₂O and CO₂.



Figure 2.7: NO_x sensing element (chip)

Direct measurement of both NO and NO₂ is the more precise way to measure Total NO_x for Continuous Emissions Monitoring and measurement in the UV-region avoids the influence of H₂O and CO₂[10]. System development based on UV Resonance Absorption Spectroscopy (UVRAS) has been difficult in the past due to challenges in tuning the UV-lamp operation with its environment.

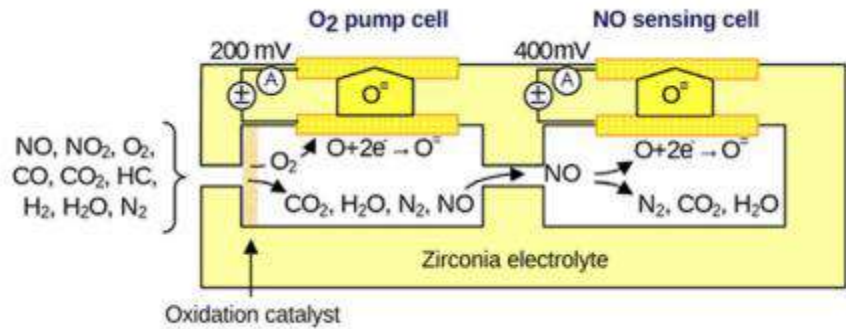

Figure 2.8: NO_x sensing element in longitudinal section view

2.3. Measured Emissions of Different Engines:

Average concentration emissions of CO, NO, SO₂, HC, and smoke opacity for different categories of vehicles using different types of fuels are given in Table:2.

For 2-stroke engines high CO emission levels were observed. For diesel car engines, CO emissions were 0.1% only. CO emission concentrations were found to be dependent both on engine and fuel type. Diesel as fuel irrespective of engine type appears to have less contribution of CO emissions; on the other hand, low carbon fuel (CNG) was found to release high CO pollution owing to less mixing of air into the gaseous fuel [12].

Table:2.2 : Comparison of mean emissions by different vehicles.

Vehicle Type	Fuel Type	CO (%)	NO (ppm)
Bus	CNG	2	45
	Diesel	0.1	82
Rickshaw	2-stroke LPG	3.5	2
	4-stroke CNG	2.5	21
	4-stroke Gasoline	2.6	15
Van	CNG	1.3	60
	Diesel	0.15	78
	Gasoline	2.4	75
Motorcycle	2-stroke gasoline	4.7	21
	4-stroke gasoline	1.6	16
Tractor	Diesel	0.4	110
Truck	Diesel	0.2	120
Car	CNG	1.6	16
	Diesel	0.1	45
	Gasoline	1.8	13

Diesel vehicle engines produced high NO emissions, for the diesel bus engine NO emissions were 1.8 times higher than the CNG bus engine (Table:2). CNG car engine emitted 2.8 times less NO (16 ppm) than that of diesel car engine (45 ppm), and 1.2 times higher than that of gasoline car engine (13 ppm). The variation in NO emissions appeared to be irrespective of the fuel types depending on the engine of the vehicle. In fact, generation of NO depends on the temperature in the engine, which converts the atmospheric N₂ to NO [13].

2.3.1 Comparison Based on Engines and Fuels:

A comparison of vehicular emissions based on fuel and engine type is shown in Figs. The diesel bus engine emitted 1.8 times higher NO emissions, as compared to the CNG bus.

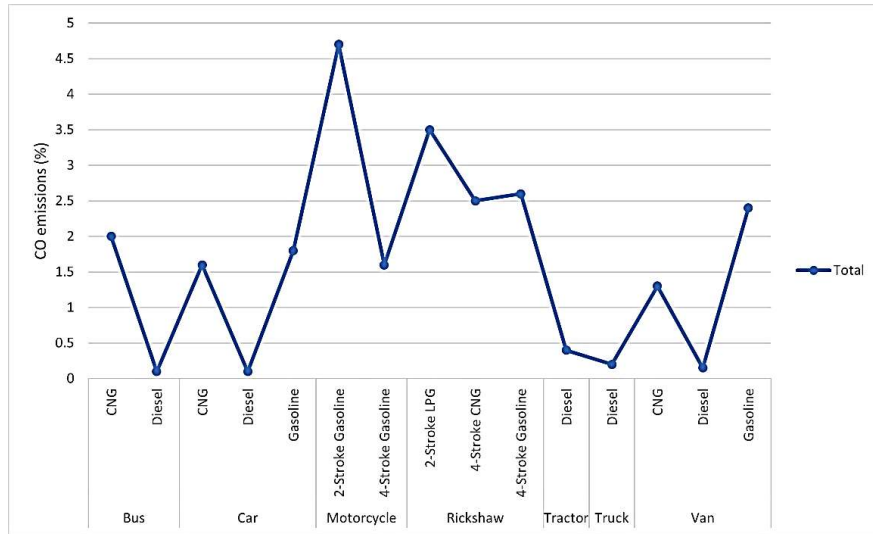

Figure 2.9: Comparison of mean emission of CO (%) based on fuel type.

In contrast, the CNG bus engine released 20 times higher CO emissions. By considering all the pollutant concentrations, a diesel bus engine produced 13.4 times higher vehicular emissions than that of the CNG bus engine (except CO).

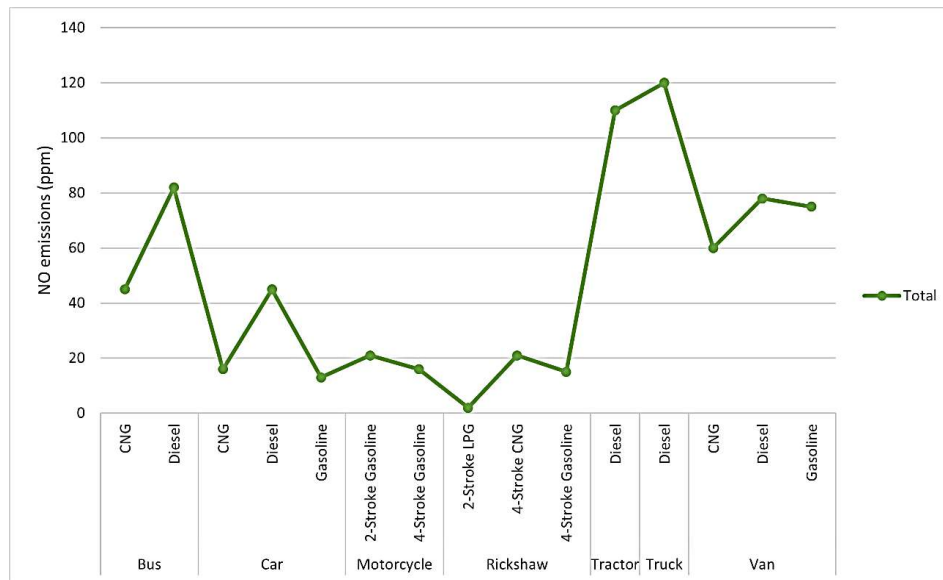

Figure 2.10: Comparison of mean emission NO based on fuel type

2.4. Why did we choose to measure only CO and NO_x:

There are several reasons why this selection can be justified:

- 1. Emission Control Focus:** CO and NO_x emissions have been the primary focus of emission control strategies for gasoline engines. The automotive industry has made significant advancements in emission control technologies specifically targeting these pollutants. By measuring CO and NO_x, you can assess the effectiveness of these emission control systems and evaluate the compliance of your vehicles with current emission standards.
- 2. Health and Environmental Impact:** While other pollutants, such as hydrocarbons (HC) and particulate matter (PM), do have their own health and environmental implications, CO and NO_x emissions are known to have immediate and severe health effects. By concentrating on these pollutants, you can prioritize the reduction of emissions that have the most immediate impact on public health, especially in highly populated areas or regions with poor air quality.
- 3. Availability of Measurement Techniques:** Measuring CO and NO_x emissions from gasoline engines is relatively easier and more established compared to other pollutants. The equipment and techniques for measuring CO and NO_x are well-developed, standardized, and readily available. This accessibility simplifies the measurement process, reduces costs, and ensures accurate and reliable data collection.
- 4. Resource Constraints:** Conducting comprehensive emissions testing that includes multiple pollutants can be resource-intensive in terms of time, equipment, and

manpower. Focusing on CO and NO_x allows for more efficient use of limited resources while still providing valuable insights into the immediate health and environmental impacts of gasoline engine emissions.

- 5. Research Focus:** If your specific research or monitoring objective is centered around the combustion process, fuel efficiency, or the performance of emission control systems, then measuring CO and NO_x emissions can provide targeted and specific data for your analysis. This approach allows you to delve deeper into understanding the combustion characteristics and emission behavior of gasoline engines without the need for extensive measurements of other pollutants.

Chapter 03: Methodology:

For Building a portable emission analyzer following steps are involved:

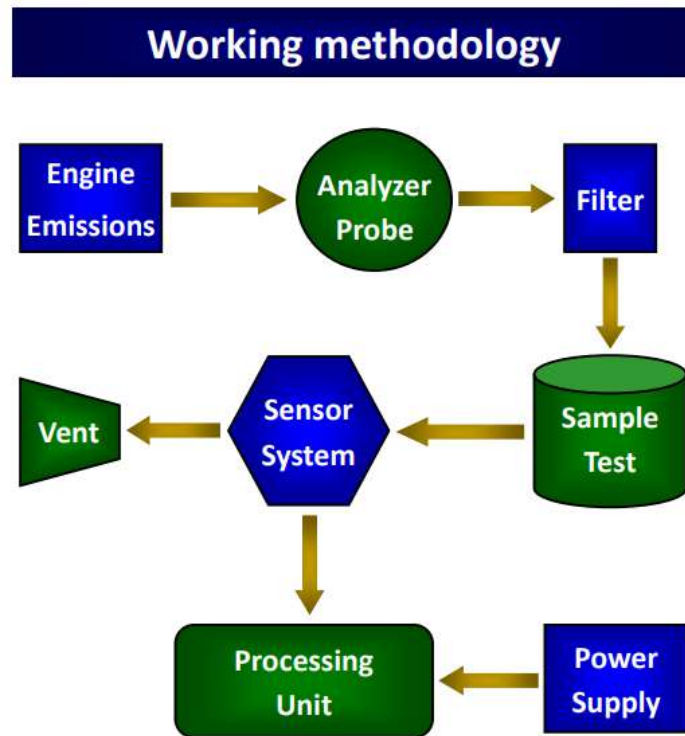

Figure 3.1: Working methodology.

3.1 Determine the pollutants of interest:

The first step in building a portable emission analyzer is to determine which pollutants want to measure. We are tending to measure Co, No and Hydrocarbon.

3.2 Choose sensors:

Once we have determined the pollutants of interest, we choose a sensor that can detect them. For NO_x we select Ns11Na and for CO we choose ZE15-CO.

3.3 Model the analyzer:

After choosing a sensor, our next step is to design the analyzer itself. This will typically involve selecting a housing for the sensor, as well as designing the electronic circuit board that will control the sensor and transmit the data it collects.



Figure 3.2: 3D model

3.4 Assemble the analyzer:

Once the design is complete, our next target is to assemble the analyzer. This will typically involve soldering the electronic components to the circuit board, and then installing the sensor and other components into the housing.

3.5 Calibrate the analyzer:

After the analyzer is assembled, the next goal is to calibrate it. This will typically involve exposing the sensor to known concentrations of the pollutants of interest, and then adjusting the electronic circuit board so that the analyzer can accurately measure those concentrations.

Calibration of Sensors:

Calibration of sensors refers to the process of adjusting and verifying the accuracy and reliability of sensor measurements by comparing them to known reference values or standards. It ensures that the sensor's output corresponds to the actual physical or chemical quantity being measured.

The calibration process involves the following steps:

Selection of Calibration Standards: The first step is to select appropriate calibration standards that closely match the properties and range of the quantity being measured. These standards should have a known and traceable value, often provided by calibration laboratories or certified reference materials.

Calibration Setup: The sensor is placed in a controlled environment or calibration setup that simulates the conditions under which it will be used. This may involve adjusting temperature, humidity, or other relevant factors to replicate the intended operating conditions.

Comparison with Reference Values: The sensor is exposed to the calibration standards or reference values, and its output readings are recorded. These readings are then compared to the known reference values to determine any systematic deviations or errors.

Adjustment and Correction: If there are discrepancies between the sensor readings and the reference values, adjustments can be made to the sensor or its associated electronics. This can involve calibration trim pots, software adjustments, or other methods to bring the sensor's output in line with the reference values.

Verification and Documentation: Once the adjustments have been made, the sensor is retested and compared to the reference values again to verify that the adjustments have been successful. The calibration process is documented, including details of the standards used, adjustments made, and the resulting calibration data.

Regular Calibration Schedule: Sensors typically require periodic calibration to account for factors such as drift over time, environmental changes, or component aging. Calibration schedules can vary depending on the sensor type, application, and manufacturer recommendations.

3.6 Test the analyzer:

Once the analyzer is calibrated, the final step is to test it to ensure that it is working properly. This will typically involve exposing the sensor to a variety of different concentrations of the pollutants of interest, and then comparing the readings to known values to ensure that the analyzer is accurate.

Chapter 04: Experimental Setup:

The experimental setup aims to measure CO and NO_x emissions from engine exhaust gases using specific components. The setup involves the use of gas sensors that react to the presence of gases, converting their concentration into meaningful measurements displayed in parts per million (PPM). The components used in the setup are as follows:

4.1 Parts:

4.1.1 Gas Sampling Pipe:

- A specialized gas sampling pipe is employed to collect a representative sample of the exhaust gases directly from the engine's exhaust pipe.
- The probe ensures that the captured gases accurately reflect the emissions being released by the engine.



Figure 4.1: Gas Sampling Pipe

4.1.2 Filtration System:

- The collected exhaust gases pass through a filtration system, removing particulate matter and impurities.
- This step ensures that the subsequent measurements focus solely on the target gases, CO and NOx, enhancing the accuracy of the analysis.

4.1.3 Gas Storage Tank (Constructed with PVC Pipe):

- A storage tank is constructed using PVC pipe to accumulate and control the release of the filtered exhaust gases.
- The PVC pipe tank provides a stable and secure environment for storing the gases during the measurement process.



Figure 4.2: Gas Storage Tank

4.1.4 Gas Sensors:

Two types of gas sensors are employed:

- **Ns11Na Sensor:** The Ns11Na sensor is specifically designed to detect and measure NO_x concentrations in the exhaust gases.



Figure 4.3: NO_x Sensor

Working Principle:

The NGK NS11A sensor, as an NO_x sensor, operates based on the principle of electrochemical sensing. It utilizes a solid-state ceramic material, typically zirconia, that acts as the sensing element.



Figure 4.4: NO_x sensing element (chip)

The working principle of the NS11A sensor can be summarized as follows:

1. **Differential Oxygen Concentration:** The NS11A sensor is in the exhaust system of an engine, where it is exposed to the exhaust gases containing oxygen. The sensor has an internal reference chamber, which is exposed to ambient air, and a measurement chamber, which is exposed to the exhaust gas.
2. **Oxygen Partial Pressure Differential:** The sensor measures the difference in oxygen partial pressure between the reference chamber and the measurement chamber. This differential oxygen concentration generates an electromotive force (EMF) or voltage signal.
3. **Ion Transport:** The zirconia-based ceramic material used in the sensor is an oxygen-ion conductor. At high temperatures (typical operating temperatures for oxygen sensors), oxygen ions from the measurement chamber migrate through the zirconia electrolyte to the reference chamber due to the oxygen partial pressure difference.

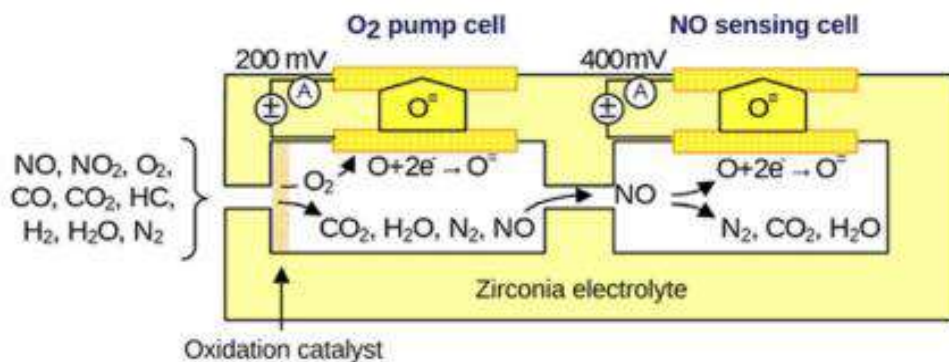

Figure 4.5: NO_x sensing element in longitudinal section view

4. **Formation of EMF:** The migration of oxygen ions creates a difference in oxygen concentration between the measurement chamber and the reference chamber. This

difference in oxygen concentration generates an EMF or voltage across the sensor electrodes.

5. Signal Output: The voltage generated by the NS11A sensor is proportional to the difference in oxygen concentration between the exhaust gas and the reference air. This voltage signal is then transmitted to the engine control unit (ECU) to monitor and adjust the air-fuel mixture for optimal combustion efficiency.

- **ZE15-CO Sensor:** The ZE15-CO sensor is dedicated to detecting and measuring CO.



Figure 4.6: CO Sensor

Working Principle:

The ZE15 CO sensor operates based on the principle of electrochemical gas sensing. It is designed to detect and measure carbon monoxide (CO) gas concentrations in the surrounding environment. The working principle of the ZE15 CO sensor can be summarized as follows:

- 1. Electrochemical Cell:** The sensor consists of an electrochemical cell, which is composed of a sensing electrode, a counter electrode, and an electrolyte. The sensing electrode is typically made of a material that reacts with CO gas.

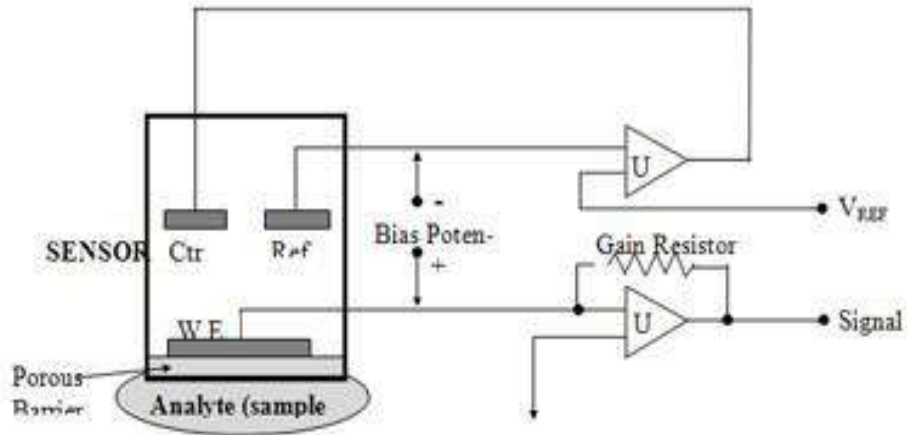

Figure 4.7: Chemical CO Sensor [8]

- 2. CO Gas Detection:** When CO gas is present, it diffuses through a gas-permeable membrane into the sensing electrode. At the sensing electrode surface, the CO molecules undergo an electrochemical reaction with the sensing material.
- 3. Electrochemical Reaction:** The electrochemical reaction at the sensing electrode results in the generation of an electrical current that is proportional to the concentration of CO gas. This current serves as the sensor's output signal.
- 4. Measurement and Analysis:** The electrical current produced by the electrochemical reaction is measured and converted into a digital signal by an integrated circuit within the sensor. This digital signal can be further processed and calibrated to provide accurate CO gas concentration readings.
- 5. Calibration and Compensation:** CO sensors like the ZE15 may require periodic calibration to ensure accuracy. Additionally, temperature and humidity

compensation may be employed to account for environmental factors that can influence the sensor's performance.

It's important to note that electrochemical CO sensors, including the ZE15, are sensitive to CO gas and can provide reliable and real-time measurements. However, they may have limitations in terms of accuracy, response time, and cross-sensitivity to other gases. Proper installation, calibration, and adherence to manufacturer guidelines are essential for optimal performance of the ZE15 CO sensor.

Table:4.1: Data Sheet of CO Sensor.

Technical Parameters Stable1.	
Model No.	ZE15-CO
Detection gas	Carbon Monoxide (CO gas)
Interfering gases	Alcohol &etc.
Output data	UART output (0 or 3V)
Working voltage	5V~12V DC
Preheating time	30S
Response time	≤30S
Recovery time	≤30S
Detection range	0~500ppm
Resolution	0.1ppm
Working temperature	-10°C~55°C
Working humidity	15%RH-90%RH (no condensation)
Storage temperature	-10°C~55°C
Life span	3-5 year (in air)

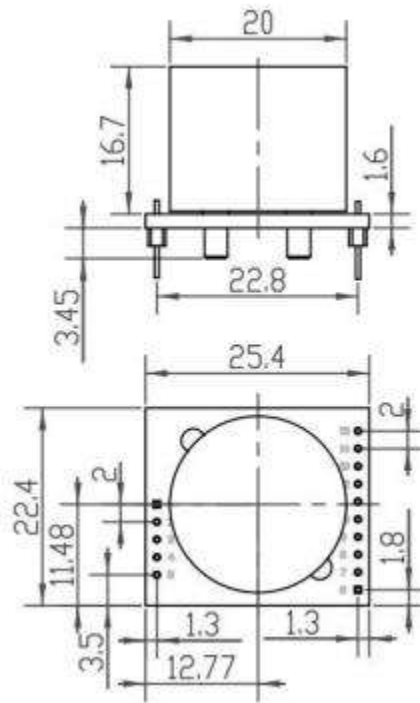

4.1.5 Temperature Module:

- A temperature module is incorporated into the setup to measure the temperature of the exhaust gases.

- This module provides additional environmental data that can be correlated with the CO and NOx concentrations for a more comprehensive analysis.



Figure 4.8: Temperature module

4.1.6 Processing Unit:

- The gas sensors and temperature module are connected to a processing unit, known as Arduino. The processing unit receives the electrical signals from the gas sensors and temperature module.



Figure 4.9: Processing Unit

- It applies calibration techniques and algorithms to convert the sensor readings into CO and NO_x concentration values in parts per million (PPM).
- The processing unit performs necessary calculations and data processing to ensure accurate measurements.
- It also consists of a Potentiometer to drop down the voltage of Ns11Na Sensor for operate it to 5v for Arduino due to its input voltage which is 12v.

4.1.7 Display Unit:

- A display unit, such as an LCD screen, is connected to the processing unit to showcase the measured CO and NO_x concentrations, as well as the temperature.
- The display unit presents the final concentration values of CO and NO_x in parts per million (PPM), providing real-time feedback and easy interpretation of emissions levels.



Figure 4.10: Display unit

4.2 Working Method:

4.2.1 Gas Sensors (Ns11Na and ZE15-CO):

- The gas sensors (Ns11Na for NO_x and ZE15-CO for CO) are typically designed as analog sensors that provide voltage outputs proportional to the detected gas concentrations.

- To read these analog voltage signals, the gas sensors are connected to the Arduino's analog input pins.
- Analog pins on the Arduino (such as A0, A1, etc.) have built-in analog-to-digital converters (ADC) that convert the continuous analog voltage signals into discrete digital values.
- The gas sensors are connected as follows:
 - The Vcc pin of each sensor is connected to a 5V power supply or the Arduino's 5V pin to provide power.
 - The GND (ground) pin of each sensor is connected to the Arduino's ground (GND) pin for reference.
 - The analog output pin of each sensor is connected to a specific analog input pin on the Arduino (e.g., A0, A1) for reading the sensor's voltage output.

The ZE15-CO module is specifically designed to detect and measure carbon monoxide (CO) gas concentrations. It incorporates a CO sensor based on electrochemical principles. The CO sensor typically contains an electrolyte and sensing electrodes. When exposed to CO gas, the CO molecules interact with the sensing electrodes, causing electrochemical reactions. These reactions generate an electrical signal, usually a voltage or current, that is proportional to the CO gas concentration.

The Ns11Na sensor is specifically designed to detect and measure nitrogen oxides (NO_x) gas concentrations. The sensor typically operates based on a chemiluminescence principle. Inside the NO_x sensor, a reaction chamber contains a catalyst material and a chemiluminescent material, usually ozone (O₃). The sensor first reacts with the incoming exhaust gases, converting NO_x to nitrogen dioxide (NO₂). The NO₂ gas then reacts with the ozone (O₃) in the reaction chamber, resulting in the emission of light. The emitted

light is detected by a photodetector within the sensor, and the intensity of the detected light is proportional to the NO_x concentration. The sensor provides an electrical signal, usually analog voltage or current, that corresponds to the NO_x concentration.

4.2.2 Temperature Module:

- The temperature module is typically a digital sensor that communicates with the Arduino using the I²C (Inter-Integrated Circuit) protocol.
- The I²C protocol requires two specific pins on the Arduino: SDA (data) and SCL (clock).
- The temperature module is connected as follows:
- The Vcc pin of the module is connected to a 5V power supply or the Arduino's 5V pin.
- The GND (ground) pin of the module is connected to the Arduino's ground (GND) pin.
- The SDA pin of the module is connected to the Arduino's dedicated SDA pin (e.g., A4).
- The SCL pin of the module is connected to the Arduino's dedicated SCL pin (e.g., A5).
- The Arduino communicates with the temperature module using the Wire library, which facilitates the I²C communication.

4.2.3 SD Card:

- The SD card is connected to the Arduino using the SPI (Serial Peripheral Interface) protocol.
- The SPI protocol involves the use of specific pins on the Arduino for communication, including MOSI (Master out Slave In), MISO (Master in Slave Out), SCK (Serial Clock), and CS (Chip Select).
- The SD card is connected as follows:

- The Vcc pin of the SD card module is connected to a 5V power supply or the Arduino's 5V pin.
- The GND (ground) pin of the SD card module is connected to the Arduino's ground (GND) pin.
- The MOSI pin of the SD card module is connected to the Arduino's dedicated MOSI pin (e.g., 11).
- The MISO pin of the SD card module is connected to the Arduino's dedicated MISO pin (e.g., 12).
- The SCK pin of the SD card module is connected to the Arduino's dedicated SCK pin (e.g., 13).
- The CS (Chip Select) pin of the SD card module is connected to a specific digital pin on the Arduino (e.g., 4) to select the SD card for communication.

Working Model:



Figure 4.11: Working Model

4.3 Code to Interact with Arduino:

```
#include "max6675.h"    (for Thermocouple Library)

#include <SPI.h>        (For communication Protocol)

#include <SD.h>         (for SD Card)

#include <Wire.h>       (for LCD)

#include <LiquidCrystal_I2C.h>
```

```

LiquidCrystal_I2C lcd (0x27,16,2);

File myFile;

int thermoDO = 7;

int thermoCS = 5;

int thermoCLK = 6;

MAX6675 thermocouple(thermoCLK, thermoCS, thermoDO);

void setup() {

    Serial.begin(9600);

    // put your setup code here, to run once:

    lcd.init();

    // Print a message to the LCD.

    lcd.backlight();

    while (!Serial) {

        ; // wait for serial port to connect. Needed for native USB port only

    }

    Serial.print("Initializing SD card...");

    if (!SD.begin(4)) {

        Serial.println("initialization failed!");

        while (1);

    }

    Serial.println("initialization done.");

    myFile = SD.open("test.txt", FILE_WRITE);

```

```

// if the file opened okay, write to it:

if (myFile) {

  Serial.print("Writing to test.txt...");

  myFile.println("Readings on interval of 2sec");

  // close the file:

  Serial.println("done.");

} else {

  // if the file didn't open, print an error:

  Serial.println("error opening test.txt");

}

}

void loop() {

  // put your main code here, to run repeatedly:

  int sensorValue = analogRead(A0);

  int sensorValue1 = analogRead(A1);

  // print out the value you read:

  int val = map(sensorValue, 77, 450, 0, 500);

  int val1 = map(sensorValue1, 0, 450, 0, 100);

  int C= thermocouple.readCelsius();

  Serial.println(val);

  lcd.setCursor(0,0);

  lcd.print("CO=");

  lcd.print(val);

  lcd.print("ppm ");

  lcd.setCursor(9,0);

```

```
lcd.print("T=");

lcd.print(C);

lcd.print("C");

  lcd.setCursor(0,1);

lcd.print("NOx=");

lcd.print(val1);

lcd.print("ppm ");

myFile.print("Co=");

myFile.print(val);

  myFile.print("ppm ,");

  myFile.print("NOx=");

myFile.print(val1);

  myFile.print("ppm ,");

  myFile.print("Temp=");

myFile.print(C);

  myFile.println("*C");

// close the file:

myFile.close();

delay(2000);

lcd.clear();

myFile = SD.open("test.txt", FILE_WRITE);

}
```

4.4 Pins Explanation:

4.4.1 thermoDO (Thermocouple Data Out):

- This pin is the data output pin of the MAX6675 thermocouple module.
- It carries the digital temperature data from the thermocouple to the Arduino.
- In the provided code, it is connected to digital pin 7 of the Arduino.

4.4.2 thermoCS (Thermocouple Chip Select):

- This pin is the chip select pin for the MAX6675 thermocouple module.
- In the SPI communication protocol, the chip select pin is used to enable or disable communication with the specific device connected to it.
- In the provided code, it is connected to digital pin 5 of the Arduino.

4.4.3 thermoCLK (Thermocouple Clock):

- This pin is the clock pin for the MAX6675 thermocouple module.
- In the SPI communication protocol, the clock pin provides synchronization for data transmission between the Arduino and the device.
- It generates a series of clock pulses that regulate the timing of data transfer.
- In the provided code, it is connected to digital pin 6 of the Arduino.

4.4.4 A0 and A1 (Analog Input Pins):

- These pins are analog input pins on the Arduino board.
- They can read analog voltage values from connected sensors.
- In the code, **analogRead(A0)** and **analogRead(A1)** are used to read analog values from these pins.

4.4.5 0x27 (I2C Address):

- This value represents the I2C address of the LCD screen.
- It is used to initialize the **LiquidCrystal_I2C** object with the correct address for communication.
- In the provided code, it is set as the I2C address of the LCD screen.

4.4.6 4 (SD Card Pin):

- This pin is used for the SPI communication with the SD card module.
- It is the chip select (CS) pin for the SD card module.
- In the provided code, the SD card module is connected to digital pin 4 of the Arduino for data transfer.

Testing:



Figure 4.12: Testing of Analyzer

Chapter 05: Results and Discussion:

We did the testing of our Analyzer by using the Honda Motorbike 70CC. Following results are observed while testing.

Table:5.1: Honda Bike emissions

Honda Bike Emissions		
Temperature	CO Emission	NOx Emission
30	1	0
33	3	2
40	33	6
50	93	18
58	211	22
66	272	32
71	384	42
73	382	54
78	383	68
80	390	76
81	420	76

5.1 Graph:

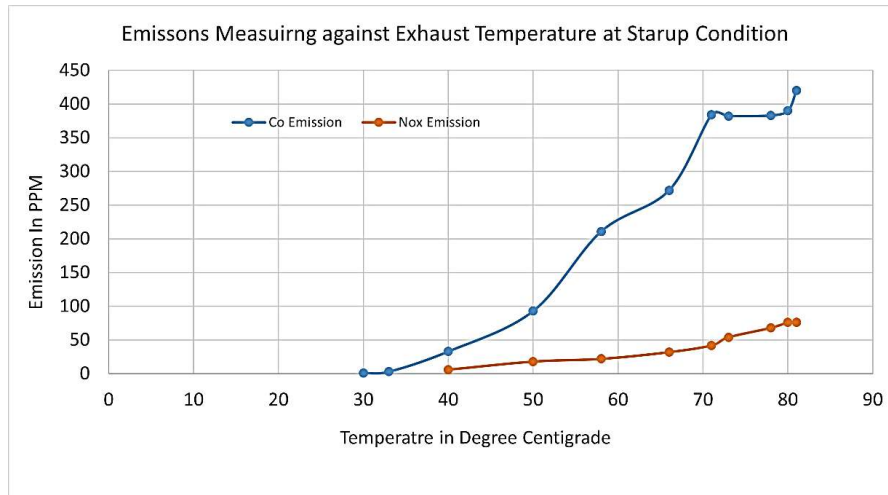

Figure 5.1: Result of Emissions

5.2 Discussion:

The experiments were conducted on a Honda 125 motorcycle to measure the emissions of CO and NO_x. The collected data includes temperature, CO emissions, and NO_x emissions. Let's discuss the results and compare them with theoretical values emitted by the engine.

Temperature:

The temperature readings were recorded during the experiments, ranging from 30°C to 81°C.

It is observed that as the temperature increases, the emissions of CO and NO_x also tend to increase. This correlation aligns with the general understanding that higher temperatures can lead to more complete combustion, resulting in increased emissions.

CO Emissions:

The CO emission values were measured during the experiments and ranged from 1 PPM to 420 PPM.

As the temperature increased, there was a noticeable increase in CO emissions. The CO emission levels observed during the experiments indicate that the Honda 125 motorcycle produces relatively low levels of CO emissions. However, the highest recorded value of 420 PPM should be further investigated to ensure it falls within the permissible limits set by emission regulations.

NO_x Emissions:

The NO_x emission values ranged from 0 PPM to 76 PPM during the experiments.

Like CO emissions, an increase in temperature resulted in increased NOx emissions. The observed NOx emission levels suggest that the Honda 125 motorcycle produces moderate levels of NOx emissions. However, further analysis is required to compare these levels against the relevant emission standards to determine compliance.

Chapter 06: Conclusion:

In this project, an engine emission analyzer was developed to measure the primary pollutants NO_x and CO in engine exhaust gases. The goal was to assess the environmental impact of engine emissions and contribute to the understanding of air pollution.

Through the implementation of gas sensors, specifically the Ns11Na sensor for NO_x and the ZE15-CO sensor for CO, accurate measurements of these pollutants were obtained. The gas sensors effectively detected the concentrations of NO_x and CO, providing valuable data for analysis.

The results obtained from the experiments on a petrol engine revealed a correlation between the measured pollutant concentrations and temperature. As the temperature increased, both CO and NO_x emissions exhibited an upward trend, highlighting the influence of combustion conditions on pollutant generation.

By monitoring and analyzing the emissions, this project contributes to the identification of potential environmental issues associated with engine exhaust gases. The collected data can aid in evaluating the performance of engines, identifying areas for improvement in emission control technologies, and establishing compliance with emission standards and regulations.

Additionally, the utilization of a temperature module provided insights into the relationship between temperature and emissions. The temperature readings demonstrated a direct impact on the levels of CO and NO_x emissions, emphasizing the importance of temperature control in minimizing pollutant generation.

The successful development of the engine emission analyzer provides a platform for future research and further improvements in emission monitoring and control. It offers the potential to expand the analysis to include other pollutants and evaluate the effectiveness of emission reduction strategies.

Overall, this project contributes to the understanding of engine emissions and their impact on air quality. By measuring and analyzing the primary pollutants NO_x and CO, it aids in raising awareness of the importance of emission control and the development of cleaner and more sustainable engine technologies.

Reference:

- [1] Paul L. Guenther, Donald H. Stedman & Jon M. Laski. Prediction of IM240 Mass Emissions Using Portable Exhaust Analyzers: Air & Waste Management Association, 09 Jan 2012
- [2] Daham Basil, Andrews, Gordon E. Application of a portable FTIR for measuring on-road emissions: White Rose Research Online, 2005, pp. 171- 192.
- [3] Michal Vojtisek-Lom, Vehicle Mass Emissions Measurement using a Portable 5Gas Exhaust Analyzer and Engine Computer Data:1997
- [4] R. S. Spinnet , Air-Fuel Ratios from Exhaust Gas Analysis:JSTOR,2004, pp. 788-793
- [5] Willard W. Pulkrabek.Engineering Fundamentals of the Internal Combustion Engine
- [6] Esa Kari Vakkilainen, in Steam Generation from Biomass, 2017
- [7] Pfeifer, J. L., T. A. Libsch, and H. P. Wertheimer. "Heated Thick-Film Exhaust Gas Oxygen Sensors." SAE Transactions 93 (1984): 848–55.
<http://www.jstor.org/stable/44468067>
- [8] W.Harry. The Theory behind Carbon Monoxide Electrochemical Sensors, coleparmer, 2018
- [9] Jun-Hong Yeah. Long Term Stable Δ - Σ NDIR Technique Based on Temperature Compensation, 2019
- [10] Hara, K., Nakatani, S., Rahman, M., Nakamura, H. et al., "Development of Nitrogen Components Analyzer Utilizing Quantum Cascade Laser," SAE Technical Paper 2009-01-2743, 2009.
- [11] A Comparison of Engine Emissions from Heavy, Medium, and Light Vehicles for CNG, Diesel, and Gasoline Fuels, Pol. J. Environ. Stud. Vol. 22, No. 4 (2013), 1277-1281
- [12] ALKAMA R., SLIMANI. Estimation and Measurement of the Automobile Pollution: Application to Bejaia Case. Global Nest. 8, 277, 2006.
- [13] SAHOO B. B., SAHOO N., SAHA U. K. Effect of engine parameters and type of gaseous fuel on the performance of dual-fuel gas diesel engines – A critical review. Renew. Sust. Energ. Rev 13, (6), 1151, 2009.